

WSH

Reversible water-cooled heat pump, gas side

Cooling capacity 165,8 ÷ 671,3 kW

Heating capacity 189,8 ÷ 812,5 kW

- Refrigerant reversing valve
- Optional electronic expansion valve which allows:
 - Cooling down to -6 °C
 - Modulating capacity control 25-100%



EUROVENT LCP

Manufactured with refrigerant R134a

Versions for cooling only - heat pump with refrigerant reversing valve

Partial heat recovery option

- **Standard Version (*)**: leaving water temperature up to 55 °C in heat pump mode
- **Version X**: leaving liquid temperature down to -6 °C
- **Version L**: low noise
- High efficiency, low noise screw compressors with modulating capacity control from 40 to 100% with standard thermostatic expansion valve. (25 to 100% with electronic expansion valve option)
- Compressor discharge and liquid line isolating valves
- Current transformer as standard for each compressor
- Dual refrigerant circuit plate heat exchanger optimised for R134a on dual compressor units
- Modulating capacity control microprocessor system
- Independent control for individual circuits
- Electrical panel with all cables numbered
- Modulating capacity control with dynamic display of refrigeration capacity
- "Always Working" function. In the case of critical conditions the unit will not stop but automatically adjusts operation
- Automatic set point compensation using analogue inputs 4-20 mA or 0-10 V or an external air sensor
- Auto-adaptive differential to ensure correct compressor operating timers

- PDC (Pull Down Control) system which prevents capacity loading when the water temperature quickly approaches the set point
- DL (Demand Limit) system permits current limiting of the unit during times of insufficient electrical power (load peaks or generator operation)
- Compact dimensions
- Multilingual display panel
- Metal control panel with anti-corrosion polyester paint

ACCESSORIES

AER485P1: RS-485 interface for supervision systems with MODBUS protocol.

AERNET: The device allows the control, the management and the remote monitoring of a Chiller with a PC, smartphone or tablet using Cloud connection. AERNET works as Master while every unit connected is configured as Slave (max. 6 unit); also, with a simple click is possible to save a log file with all the connected unit datas in the personal terminal for post analysis.

MULTICHILLER_EVO: Control system for multiple parallel installed constant flow chillers providing individual chiller on/off and control capability.

PRV3: Remote control of the chiller operating functions.

AKW: ACOUSTIC KIT: Allows further unit sound reduction using an optimised enclosure made from a high density ecological material.

AVX: Spring anti-vibration mounts.

RIF: Power factor correction. Connected in parallel to the motor allowing about 10% reduction of input current. Must be requested at time of order and is available factory fitted only.

SAP: A series of remote buffer tanks and pumps are available. Refer to the technical manual.

ACCESSORIES COMPATIBILITY

Model	Vers.	0701	0801	0901	1101	1402	1602	1802	2002	2202	2502
AER485P1		•	•	•	•	•(x2)	•(x2)	•(x2)	•(x2)	•(x2)	•(x2)
AERNET		•	•	•	•	•	•	•	•	•	•
MULTICHILLER_EVO		•	•	•	•	•	•	•	•	•	•
PRV3		•	•	•	•	•	•	•	•	•	•
AKW	L	•	•	•	•	•	•	•	•	•	•

AVX: Antivibration

Vers.	0701	0801	0901	1101	1402	1602	1802	2002	2202	2502
°/L	AVX665	AVX665	AVX665	AVX666	AVX662	AVX662	AVX662	AVX663	AVX664	AVX664
D	AVX665	AVX665	AVX665	AVX666	AVX662	AVX662	AVX662	AVX663	AVX664	AVX664

RIF: Power factor correction

Vers.	0701	0801	0901	1101	1402	1602	1802	2002	2202	2502
°/L	RIF161	RIF161	RIF201	RIF241	RIF161(x2)	RIF161(x2)	RIF201(x2)	RIF201-241	RIF241(x2)	RIF301(x2)

A grey background indicates the accessories assembled in the factory

CONFIGURATOR

Field	Description
1,2,3	WSH
4,5,6,7	Size 0701, 0801, 0901, 1101, 1402, 1602, 1802, 2002, 2202, 2502
8	Expansion device
°	Standard, minimum leaving water temperature down to +4 °C
X	With electronic expansion valve that allows: Leaving liquid temperature down to -6 °C For different temperature please contact the factory.
9	Model
°	Standard
10	Heat recovery
°	Without heat recovery
D	With desuperheaters (partial heat recovery)

Field	Description
11	Version
°	Standard
L	Low noise
	Condenser
°	PED regulation
12	Power supply
°	400V 3~ 50Hz
8	400V 3~ 50Hz with circuit breakers
2	230V 3~ 50Hz with fuses
4	230V 3~ 50Hz with circuit breakers ⁽¹⁾
5	500V 3~ 50Hz with fuses
9	500V 3~ 50Hz with circuit breakers

(1) Not available for size 2502

PERFORMANCE SPECIFICATIONS

Size		0701	0801	0901	1101	1402	1602	1802	2002	2202	2502
Cooling performance 12 °C / 7 °C⁽¹⁾											
Cooling capacity	(1) kW	165,8	195,7	216,7	269,7	359,6	427,5	465,5	525,4	593,4	671,3
Total input power	(1) kW	37,1	42,3	48,3	58,8	79,2	92,0	103,5	114,9	127,1	146,9
Cooling total input current	(1) A	65	73	81	100	135	147	162	188	210	242
EER	(1) W/W	4,47	4,63	4,48	4,59	4,54	4,65	4,50	4,57	4,67	4,57
Water flow rate system side	(1) l/h	28520	33675	37283	46389	61852	73535	80064	90372	102055	115457
Pressure drops	(1) kPa	23	24	22	27	43	47	48	59	65	74
Water flow rate source side	(1) l/h	34668	40686	45310	56133	74844	88594	96984	109020	122605	139074
Pressure drops	(1) kPa	30	31	30	36	57	62	65	79	88	101
Power supply		400V/3/50Hz	400V/3/50Hz	400V/3/50Hz	400V/3/50Hz	400V/3/50Hz	400V/3/50Hz	400V/3/50Hz	400V/3/50Hz	400V/3/50Hz	400V/3/50Hz
Heating performance 40 °C / 45 °C⁽²⁾											
Heating capacity	(2) kW	189,8	217,7	245,7	310,9	435,3	507,9	559,7	642,6	725,4	812,5
Total input power	(2) kW	45,9	52,1	59,3	75,3	104,2	123,6	133,3	154,2	174,3	190,9
Heating total input current	(2) A	82	92	102	132	180	212	223	259	293	323
COP	(2) W/W	4,13	4,18	4,14	4,13	4,18	4,11	4,20	4,17	4,16	4,26
Water flow rate system side	(2) l/h	32925	37783	42641	53976	75567	88161	97157	111551	125945	141058
Pressure drops	(2) kPa	26	25	25	31	61	67	68	77	85	97
Water flow rate source side	(2) l/h	42166	48522	54604	69160	97592	113401	125750	144248	163020	184074
Pressure drops	(2) kPa	46	46	43	55	82	89	89	98	110	122
Power supply		400V/3/50Hz	400V/3/50Hz	400V/3/50Hz	400V/3/50Hz	400V/3/50Hz	400V/3/50Hz	400V/3/50Hz	400V/3/50Hz	400V/3/50Hz	400V/3/50Hz

(1) Date 14511:2018; Water user side 12 °C / 7 °C; Water source side 30 °C / 35 °C

(2) Date 14511:2018; Water user side 40 °C / 45 °C; Water source side 10 °C / 7 °C

ENERGY DATA

Size		0701	0801	0901	1101	1402	1602	1802	2002	2202	2502
Cooling capacity with low leaving water temp											
SEER	W/W	5,04	5,47	5,29	5,22	4,82	4,90	4,77	4,70	4,70	4,53
η_{sc}	%	193,5	210,7	203,4	200,7	184,8	187,9	182,6	180,1	180,1	173,2
Performance under average climatic conditions (Average) Efficiency Energy Class in according to regulation n°813/2013 Pdesignh \leq 400kW for average temperature Applications (55°C)											
Pdesignh	kW	249	285	322	/	/	/	/	/	/	/
SCOP		4,20	4,25	4,23	/	/	/	/	/	/	/
η_{sh}	%	160	162	161	/	/	/	/	/	/	/

ELECTRICAL DATA

Size		0701	0801	0901	1101	1402	1602	1802	2002	2202	2502
Electrical data											
Maximum current (FLA)	A	124	144	162	182	248	288	324	344	364	430
Peak current (LRA)	A	163	192	229	300	287	336	391	462	482	575

GENERAL TECHNICAL DATA

Size		0701	0801	0901	1101	1402	1602	1802	2002	2202	2502
Compressor											
Compressor	type	Twin-Screw	Twin-Screw	Twin-Screw	Twin-Screw	Twin-Screw	Twin-Screw	Twin-Screw	Twin-Screw	Twin-Screw	Twin-Screw
Compressors / Circuit	n°/n°	1/1	1/1	1/1	1/1	2/2	2/2	2/2	2/2	2/2	2/2
Refrigerant	type	R134a									
Heat exchanger system side											
Exchanger	type/n°	Plates/1									
Hydraulic connections (in/out)	type/ \varnothing	3"	3"	3"	3"	3"	3"	3"	3"	3"	3"
Heat exchanger source side											
Exchanger	type/n°	Plates/1									
Hydraulic connections (in/out)	type/ \varnothing	3"	3"	3"	3"	3"	3"	3"	3"	3"	3"
Sound data (cooling mode)⁽¹⁾											
Sound power level	dB(A)	86	86	86	92	89	89	89	93	95	95
Sound pressure level	dB(A)	54	54	54	60	57	57	57	61	63	63

(1) Sound power Aermec determines sound power values on the basis of measurements made in accordance with UNI EN ISO 9614-2, as required for Eurovent certification. Sound pressure Sound pressure in free field, at 10 m distance from the external surface of the unit (in accordance with UNI EN ISO 3744).

■ Note: For more information, refer to the selection program or the technical documentation available on the website www.aermec.com

DIMENSIONS

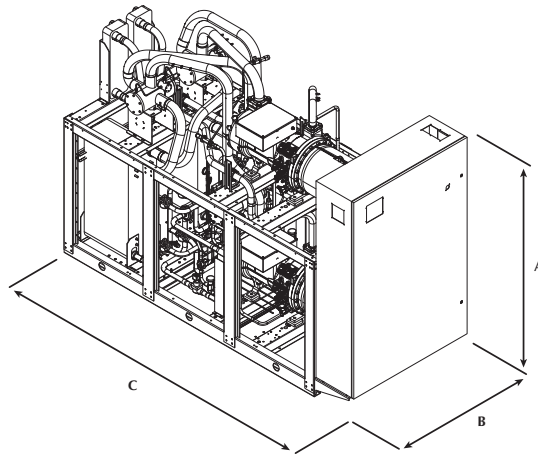

Size	Version		0701	0801	0901	1101	1402	1602	1802	2002	2202	2502
Dimensions and weights												
A	°	mm	1980	1980	1980	2060	2000	2000	2000	2000	2060	2060
	L	mm	2120	2120	2120	2120	2120	2120	2120	2120	2120	2120
B	°	mm	810	810	810	810	1260	1260	1260	1260	1260	1260
	L	mm	2960	2960	2960	3360	3060	3060	3060	3460	3460	3460
C	°	kg	1391	1443	1506	1946	2276	2350	2423	2872	3309	3407
	D	kg	1622	1674	1737	2200	2542	2616	2689	3168	3605	3703

Aermec reserves the right to make any modifications deemed necessary. All data is subject to change without notice. Aermec does not assume responsibility or liability for errors or omissions.

Aermec S.p.A.

Via Roma, 996 - 37040 Bevilacqua (VR) - Italia
Tel. 0442633111 - Telefax 044293577
www.aermec.com